

Large Sound Volume Buzzer

BS-50HS, BS-50H

High sound volume unit is a device which detects shock and tilt and emit high sound volume of around 100dB. Moreover, it is waterproof, small as a cigarette package and inexpensive, thus it being best-suited to alarm devices for preventing crimes for use in safes, automatic vending machines and the like.

BS-50HS



BS-50H

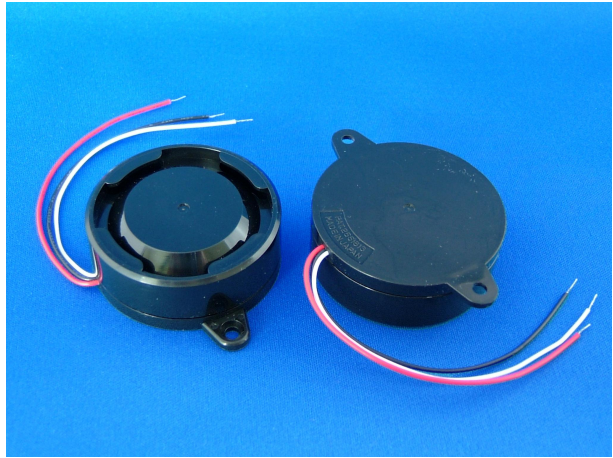

	BS-50HS	BS-50H
Sound Pressure	95+/-5 dB/1m (@12V)	110+/-5 dB/1m (@6V)
Oscillating Frequency	2kHz - 3kHz Sweep	2kHz - 4kHz Sweep
Current Consumption	25mA or less (@12V)	150mA or less (@12V)
Operating Voltage	6V ~ 16V	4.5V ~ 12V
Operating Temperature	-20°C ~ +70 °C	-20°C ~ +70 °C
Case Material	Heat Resistant ABS	Heat Resistant ABS
Weight	Approx. 30 g	Approx. 34 g
Other		Controllable by CMOS

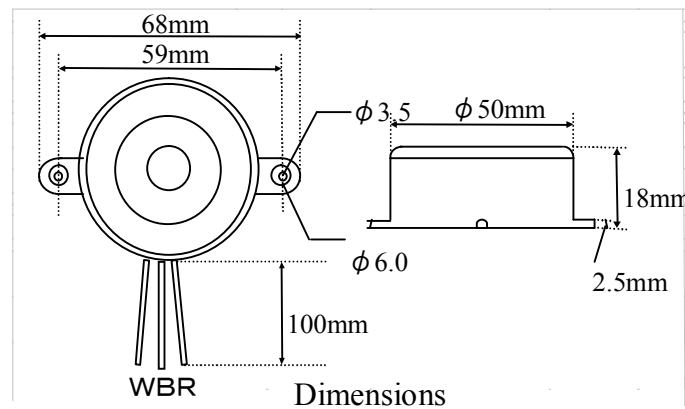

NIHON CERATEC CO.,LTD.

7-12-18,Daiichi Ginza Bldg.3F,Ginza,Chuo-ku,Tokyo,104-0061 Japan TEL. +81-3-5565-6262 FAX. +81-3-5565-6270
2700 Augustine, Suite 101, Santa Clara, CA 95054, USA TEL. +1-408-567-0347 FAX. +1-408-567-0357
<http://www.ceratecinc.com/> E-mail : sv@ceratecinc.com